

Product Preview

System Basis Chip Lite with Low Speed Fault Tolerant CAN Interface

The MC33889 is a monolithic integrated circuit combining many functions frequently used by automotive ECUs. It incorporates a low speed fault tolerant CAN physical interface.

Main features:

- Vdd1: 5V Low drop voltage regulator, current limitation, over temperature detection, monitoring and reset function. Total current capability 200mA.
- V2: Tracking function of Vdd1 regulator. Control circuitry for external bipolar ballast transistor for high flexibility in choice of peripheral voltage and current supply.
- Four operational modes: normal, stand-by, stop and sleep modes.
- Low stand-by current consumption in stop and sleep modes
- Built in Low speed 125Kbaud fault tolerant CAN physical interface, compatible with Motorola MC33388.
- External high voltage wake-up input, associated with HS1 Vbat switch
- 150mA output current capability for HS1 Vbat switch allowing drive of external switches pull up resistors or relays
- Vsup monitoring and failure detection
- DC Operating voltage from 5 to 27V
- 40V maximum transient voltage
- Programmable software time out and window watchdog
- Separate outputs for Watchdog time out signal (WDOGB) and Reset (Reset).
- Wake up capabilities: wake up input, programmable cyclic sense, forced wake up, CAN interface, SPI (CSB pin) and stop mode over current.
- Interface with MCU through 4 Mhz SPI.
- SO28WB package with thermal enhanced lead frame.

PC33889

PASS3

System Basis Chip Lite

SILICON MONOLITHIC INTEGRATED CIRCUIT

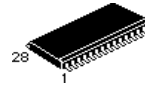

DW SUFFIX
PLASTIC PACKAGE
CASE 751F
SO-28

PIN CONNECTIONS

RX	1	0	28	WDOGB
TX	2		27	CSB
Vdd1	3		26	MOSI
Reset	4		25	MISO
INTB	5		24	SCLK
GND	6		23	GND
GND	7		22	GND
GND	8		21	GND
GND	9		20	GND
V2ctrl	10		19	CANL
Vsup	11		18	CANH
HS1	12		17	Rtl
L0	13		16	Rth
L1	14		15	V2

Simplified Block Diagram

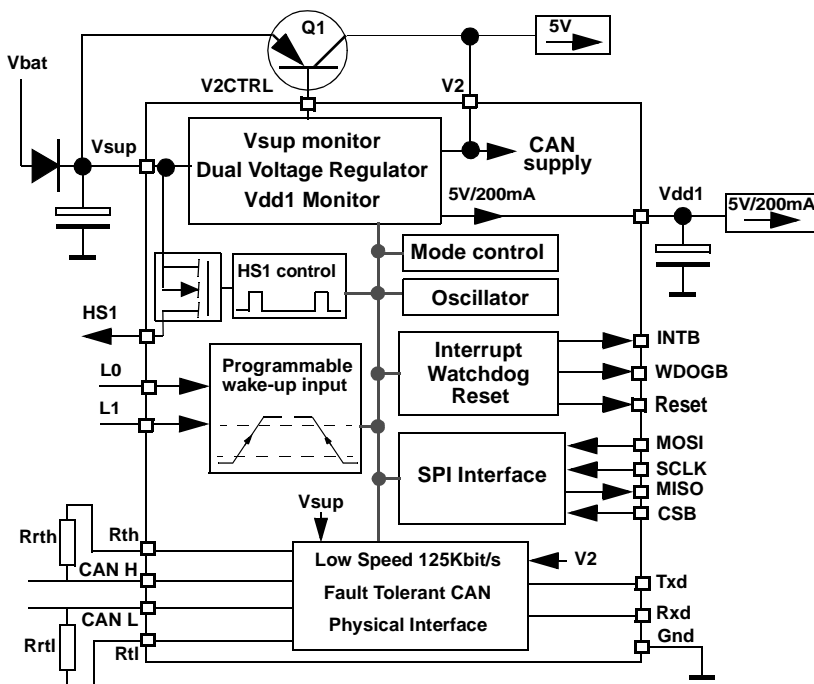

ORDERING INFORMATION

Device	Operating Temperature Range	Package
PC33889DW	T _A = -40 to 125°C	SO-28

This document contains information on a product under development. Motorola reserves the right to change or discontinue this product without notice.



1 MAXIMUM RATINGS

Ratings	Symbol	Min	Typ	Max	Unit
---------	--------	-----	-----	-----	------

ELECTRICAL RATINGS

Supply Voltage at Vsup - Continuous voltage - Transient voltage (Load dump)	Vsup Vsup	-0.3		27 40	V
Logic Inputs (Rx, Tx, MOSI, MISO, CSB, SCLK, Reset, WDOGB, INTB)	Vlog	-0.3		Vdd1+0.3	V
Output current Vdd1	I		Internally limited		A
HS1 - voltage - output current	V I	-0.2	Internally limited	Vsup+0.3	V A
ESD voltage (HBM 100pF, 1.5k) - CANL, CANH, Rtl, Rth, HS1, L0, L1 - All other pins	Vesdh	-4 -2		4 2	kV
ESD voltage (Machine Model) All pins	Vesdm	-200		200	V
L0, L1 - DC Input voltage - DC Input current - Transient input current (according to ISO7637 specification) and with external component tbd.	Vwu DC	-0.3 -2 tbd		40 2 tbd	V mA mA
CAN related pins: CANH, CANL, RTL, RTH, Tx, Rx (refer to CAN section)					

THERMAL RATINGS

Junction Temperature	T _j	-40		+150	°C
Storage Temperature	T _s	-55		+165	°C
Ambient Temperature (for info only)	T _a	-40		+125	°C
Thermal resistance junction to gnd pin (note 1)	Rthj/p			20	°C/W

Note 1: gnd pins 6,7,8,9,20, 21, 22, 23.

Figure 1. Transient test pulse for L0 and L1 inputs

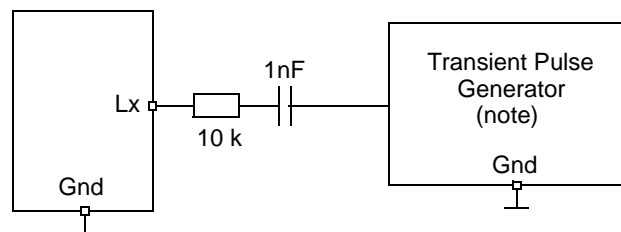

note: Waveform in accordance to ISO7637 part1, test pulses 1, 2, 3a and 3b.

2 ELECTRICAL CHARACTERISTICS

(V_{sup} From 5.5V to 18V and T_j from -40°C to 125°C) unless otherwise noted. For all pins except can related pins

Description	Symbol	Characteristics			Unit	Conditions
		Min	Typ	Max		
Vsup pin (Device power supply)						
Nominal DC Voltage range	Vsup	5.5		18	V	
Extended DC Voltage range 1	Vsup-ex1	4.5		5.5	V	Reduced functionality (note 1)
Extended DC Voltage range 2	Vsup-ex2	18		27	V	(note 3)
Input Voltage during Load Dump	VsupLD			40	V	Load dump situation
Input Voltage during jump start	VsupJS			27	V	Jump start situation
Supply Current in Sleep Mode (note 2,4)	I _{sup} (sleep1)		75	tbd	uA	Vdd1 & V2 off, Vsup<12V, oscillator running (note 5) excluding CAN current
Supply Current in Sleep Mode (note 2,4)	I _{sup} (sleep2)		60	tbd	uA	Vdd1 & V2 off, Vsup<12V oscillator not running (note5) excluding CAN current,
Supply current in sleep mode (note 2,4)	I _{sup} (sleep3)		150	tbd	uA	Vdd1 & V2 off, Vsup>12V oscillator running (note 5) excluding CAN current
Supply Current in Stand-by Mode (note 2,4)	I _{sup} (stdby)			15	mA	Iout at Vdd1 =10mA, CAN recessive state or disabled
Supply Current in Normal Mode (note 2)	I _{sup} (norm)			15	mA	Iout at Vdd1 =10mA, CAN recessive state or disabled
Supply Current in Stop mode (note 2,4) Iout Vdd1 <2mA	I _{sup} (stop1)		120	tbd	uA	Vdd1 on (note 6), Vsup<12V oscillator running (note 5) excluding CAN current,
Supply Current in Stop mode (note 2,4) Iout Vdd1 < 2mA	I _{sup} (stop2)		110	tbd	uA	Vdd1 on (note 6), Vsup<12V oscillator not running (note 5) excluding CAN current
Supply Current in Stop mode (note 2,4) Iout Vdd1 < 2mA	I _{sup} (stop3)		180	tbd	uA	Vdd1 on (note6), Vsup>12 oscillator running (note 5) excluding CAN current
Supply Fail Flag internal threshold	Vthresh	1.5	3	4	V	
Supply Fail Flag hysteresis	Vdet hyst		1		V	guaranteed by design
Battery fall early warning threshold	BFew	5.9	6.1	6.3	V	In normal & standby mode
Battery fall early warning hysteresis	BFewh	0.1	0.2	0.3	V	In normal & standby mode, guaranteed by design

note 1: Vdd1>4V, reset high, logic pin high level reduced, device is functional.

note 2: current measured at Vsup pin.

note 3: Device is fully functional. All modes available and operating, Watchdog, HS1 turn ON turn OFF, CAN cell operating, L0 and L1 inputs operating, SPI read write operation. Over temperature may occur.

note 4: Excluding the CAN cell current. An additional 30uA typical must be added to specified value.

note 5: Oscillator running means "Forced Wake Up" or "Cyclic Sense" or "Software Watchdog" timer activated.

note 6: Vdd is ON with 2mA typical output current capability.

Vdd1 (external 5V output for MCU supply). Idd1 is the total regulator output current. Vdd specification with external capacitor C>=22uF and ESR<10 ohm.

Vdd1 Output Voltage	Vdd1out	4,9	5	5,1	V	Idd1 from 2 to 200mA 5.5V < Vsup < 27V
Vdd1 Output Voltage	Vdd1out	4			V	Idd1 from 2 to 200mA 4.5V < Vsup < 5.5V
Drop Voltage Vsup>Vddout	Vdd1drop		0.2	0,5	V	Idd1 = 200mA
Drop Voltage Vsup>Vddout, limited output current	Vdd1dp2		0,1	0,25	V	Idd1 = 50mA 4.5V < Vsup < 27V
Idd1 Output Current	Idd1	200	270	350	mA	Internally limited
Vdd1 Output Voltage in stop mode	Vddstop	4,75	5,00	5,25	V	Iout < 2mA

(V_{sup} From 5.5V to 18V and T_j from -40°C to 125°C) unless otherwise noted. For all pins except can related pins

Description	Symbol	Characteristics			Unit	Conditions
		Min	Typ	Max		
I _{dd1} stop output current to wake up SBC	I _{dd1s-wu1}	2	3.5	5	mA	Selectable by SPI. Default value after reset.
I _{dd1} stop output current to wake up SBC	I _{dd1s-wu2}	10	14	18	mA	Selectable by SPI
I _{dd1} over current wake deglitcher (with I _{dd1s-wu1} selected)	I _{dd1-dglt1}	40	75	55	us	Guaranteed by design
I _{dd1} over current wake deglitcher (with I _{dd1s-wu2} selected)	I _{dd1-dglt2}		150		us	Guaranteed by design
Thermal Shutdown	T _{sd}	160		190	°C	Normal or standby mode
Over temperature pre warning	T _{pw}	130		160	°C	VDDTEMP bit set
Temperature Threshold difference	T _{sd-Tpw}	20		40	°C	
Reset threshold 1	R _{st-th1}	4.5	4.6	4.7		Selectable by SPI. Default value after reset.
Reset threshold 2	R _{st-th2}	4.1	4.2	4.3		Selectable by SPI
Reset duration	reset-dur	0.85	1	2	ms	
V _{dd1} range for Reset Active	V _{ddr}	1			V	
Reset Delay Time	t _d	5		20	us	measured at 50% of reset signal. Guaranteed by design
Line Regulation	LR1		5	25	mV	9V < V _{sup} < 18, I _{dd} = 10mA
Line Regulation	LR2		10	25	mV	5.5V < V _{sup} < 27V, I _{dd} = 10mA
Load Regulation	LD		20	50	mV	1mA < I _{dd} < 200mA
Thermal stability	ThermS		5		mV	V _{sup} = 13.5V, I = 100mA

V2 tracking voltage regulator

note 7: V2 specification with external capacitor

- option 1: C >= 22uF and ESR < 10 ohm

- option 2: 1uF < C < 22uF and ESR < 10 ohm. In this case depending upon ballast transistor gain an additional resistor and capacitor network between emitter and base of PNP ballast transistor might be required.

V2 Output Voltage	V2	0.99	1	1.01	V _{dd1}	I ₂ from 2 to 200mA 5.5V < V _{sup} < 27V
I ₂ output current (for information only)	I ₂	200			mA	Depending upon external ballast transistor
V2 ctrl drive current	I _{2ctrl}	tbd	10	tbd	mA	

Logic output pins (MISO)

Low Level Output Voltage	V _{ol}			1.0	V	I _{out} = 1.5mA
High Level Output Voltage	V _{oh}	V _{dd1} -0.9			V	I _{out} = -250uA
Tristated MISO Leakage Current		-2		+2	uA	0V < V _{miso} < V _{dd}

Logic input pins (MOSI, SCLK, CSB)

High Level Input Voltage	V _{ih}	0.7V _{dd1}		V _{dd1} +0.3V		
Low Level Input Voltage	V _{il}	-0.3		0.3V _{dd1}	V	
High Level Input Current on CSB	I _{ih}	-100		-20	uA	V _i = 4V
Low Level Input Current CSB	I _{il}	-100		-20	uA	V _i = 1V
MOSI, SCLK Input Current	I _{in}	-10		10	uA	0 < V _{IN} < V _{dd}

Reset Pin (output pin only)

High Level Output current	I _{oh}		-250		uA	0 < V _{out} < 0.7V _{dd}
Low Level Output Voltage (I _o = 1.5mA)	V _{ol}	0		0.9	V	5.5V < V _{sup} < 27V
Low Level Output Voltage (I _o = tbd mA)	V _{ol}	0		0.9	V	1V < V _{dd1}
Reset pull down current	I _{pdw}	2.4		5	mA	
Reset Duration after V _{dd} High	reset-dur	1		2	ms	

Wdogb output pin

(V_{sup} From 5.5V to 18V and T_j from -40°C to 125°C) unless otherwise noted. For all pins except can related pins

Description	Symbol	Characteristics			Unit	Conditions
		Min	Typ	Max		
Low Level Output Voltage (I _o =1.5mA)	V _{ol}	0		0.9	V	5.5V<V _{sup} <27V
High Level Output Voltage (I _o =-250uA)	V _{oh}	V _{dd1} -0.9		V _{dd1}		

INT Pin

Low Level Output Voltage (I _o =1.5mA)	V _{ol}	0		0.9	V	
High Level Output Voltage (I _o =-250uA)	V _{oh}	V _{dd1} -0.9		V _{dd1}		

HS1: 150mA High side output pin

R _{dson} at T _j =25°C, and I _{out} -150mA	R _{dson25}			2.5	Ohms	V _{sup} >9V
R _{dson} at T _j =125°C, and I _{out} -150mA	R _{dson125}			5	Ohms	V _{sup} >9V
R _{dson} at T _j =125°C, and I _{out} -120mA	R _{on125-2}		4	5.5	Ohms	5.5V<V _{sup} <9V
Output current limitation	I _{lim}	200		500	mA	
Over temperature Shutdown	O _{vt}	155		190	°C	
Leakage current	I _{leak}			10	uA	
Output Clamp Voltage at I _{out} = -1mA	V _{cl}	-1.5		-0.3	V	no inductive load drive capability
Cyclic sense period (refer to SPI)	T ₁				ms	in sleep and stop modes
Cyclic sense On time (refer to SPI)	T ₂		100		us	in sleep and stop modes
Timing accuracy (cyclic sense period and on time)	T _{acc}	-30		+30	%	in sleep and stop mode

L0 and L1 inputs

L0 Negative Switching Threshold	V _{th0n}	1.7	tbd	3	V	5.5V<V _{sup} <6V 6V<V _{sup} <18V 18V<V _{sup} <27V
		2		3		
		2	tbd	3.1		
L0 Positive Switching Threshold	V _{th0p}	2.2	tbd	4	V	5.5V<V _{sup} <6V 6V<V _{sup} <18V 18V<V _{sup} <27V
		2.5		4		
		2.5	tbd	4.1		
L1 Negative Switching Threshold	V _{th1n}	2	2.5	3	V	5.5V<V _{sup} <6V 6V<V _{sup} <18V 18V<V _{sup} <27V
		2.5	3	3.6		
		2.7	3.2	3.7		
L1 Positive Switching Threshold	V _{th1p}	2.7	3.3	3.8	V	5.5V<V _{sup} <6V 6V<V _{sup} <18V 18V<V _{sup} <27V
		3	4	4.6		
		3.5	4.2	4.7		
Hysteresis	V _{hyst}	0.6	tbd	1.3	V	5.5V<V _{sup} <18V 18V<V _{sup} <27V
Input current	I _{in}	-10		10	uA	-0.2V < V _{in} < 40V
Wake up Filter Time (enable/disable option on L0 input)		8	20	38	us	(If filter enable)

DIGITAL INTERFACE TIMING

SPI operation frequency	Freq			4	MHz	
SCLK Clock Period	t _{pCLK}	250			ns	
SCLK Clock High Time	t _{wSCLKH}	125			ns	
SCLK Clock Low Time	t _{wSCLKL}	125			ns	
Falling Edge of CS to Rising Edge of SCLK	t _{lead}	100	50		ns	
Falling Edge of SCLK to Rising Edge of CS	t _{lag}	100	50		ns	
MOSI to Falling Edge of SCLK	t _{SISU}	40	25		ns	
Falling Edge of SCLK to MOSI	t _{SIH}	40	25		ns	
MISO Rise Time (CL = 220pF)	t _{rSO}		25	50	ns	
MISO Fall Time (CL = 220pF)	t _{fSO}		25	50	ns	

(V_{sup} From 5.5V to 18V and T_j from -40°C to 125°C) unless otherwise noted. For all pins except can related pins

Description	Symbol	Characteristics			Unit	Conditions
		Min	Typ	Max		
Time from Falling or Rising Edges of CS to: - MISO Low Impedance - MISO High Impedance	t _{SOEN} t _{SODIS}			50 50	ns	
Time from Rising Edge of SCLK to MISO Data Valid	t _{valid}			50	ns	0.2 V ₁ ≤ SO ≤ 0.8 V ₁ , C _L = 200pF

STATE MACHINE TIMING**note 1: delay starts at rising edge of CSB (end of SPI command) and start of Turn on or Turn off of HS1 or V2.**

Delay between CSB low to high transition (at end of SPI stop command) and Stop or sleep mode activation	T _{csb-stop}	18		34	us	Guaranteed by design detected by V2 off
Interrupt low level duration	T _{int}	7	10	13	us	SBC in stop mode
Internal oscillator frequency	Osc-f1		100		kHz	All modes except Sleep and Stop, guaranteed by design
Internal low power oscillator frequency	Osc-f2		100		kHz	Sleep and Stop modes, guaranteed by design
Watchdog period 1	Wd1	8.58	9.75	10.92	ms	Normal and standby modes
Watchdog period 2	Wd2	39.6	45	50.4	ms	Normal and standby modes
Watchdog period 3	Wd3	88	100	112	ms	Normal and standby modes
Watchdog period 4	Wd4	308	350	392	ms	Normal and standby modes
Watchdog period accuracy	F1acc	-12		12	%	Normal and standby modes
Normal request mode timeout	NR _{tout}	308	350	392	ms	Normal request mode
Watchdog period 1 - stop	Wd1stop	6.82	9.75	12.7	ms	Stop mode
Watchdog period 2 - stop	Wd2stop	31.5	45	58.5	ms	Stop mode
Watchdog period 3 - stop	Wd3stop	70	100	130	ms	Stop mode
Watchdog period 4 - stop	Wd4stop	245	350	455	ms	Stop mode
Stop mode watchdog period accuracy	F2acc	-30		30	%	Stop mode
Cyclic sense/FWU timing 1	CSFWU1	3.22	4.6	5.98	ms	Sleep and stop modes
Cyclic sense/FWU timing 2	CSFWU2	6.47	9.25	12	ms	Sleep and stop modes
Cyclic sense/FWU timing 3	CSFWU3	12.9	18.5	24	ms	Sleep and stop modes
Cyclic sense/FWU timing 4	CSFWU4	25.9	37	48.1	ms	Sleep and stop modes
Cyclic sense/FWU timing 5	CSFWU5	51.8	74	96.2	ms	Sleep and stop modes
Cyclic sense/FWU timing 6	CSFWU6	66.8	95.5	124	ms	Sleep and stop modes
Cyclic sense/FWU timing 7	CSFWU7	134	191	248	ms	Sleep and stop modes
Cyclic sense/FWU timing 8	CSFWU8	271	388	504	ms	Sleep and stop modes
Cyclic sense On time	T _{on}	200	350	500	us	in sleep and stop modes threshold and condition to be added
Cyclic sense/FWU timing accuracy	T _{acc}	-30		+30	%	in sleep and stop mode
Delay between SPI command and HS1 turn on (note 1)	T _{s-HSon}			22	us	Normal or standby mode V _{sup} > 9V
Delay between SPI command and HS1 turn off (note 1)	T _{s-HSoff}			22	us	Normal or standby mode V _{sup} > 9V
Delay between SPI and V2 turn on (note 1)	T _{s-V2on}	9		22	us	Standby mode
Delay between SPI and V2 turn off (note 1)	T _{s-V2off}	9		22	us	Normal modes
Delay between Normal Request and Normal mode, after W/D trigger command	T _{s-NR2N}	15	35	70	us	Normal request mode

Delay between SPI and "CAN normal mode"	Ts-CANn			10	us	SBC Normal mode guaranteed by design
Delay between SPI and "CAN sleep mode"	Ts-CANs			10	us	SBC Normal mode guaranteed by design
Delay between CSB wake up (CSB low to high) and SBC normal request mode (Vdd1 on & reset high)	Tw-csb	15	40	90	us	SBC in stop mode
Delay between CSB wake up (CSB low to high) and first accepted SPI command	Tw-spi	90		N/A	us	SBC in stop mode
Delay between INT pulse and 1st SPI command accepted	Ts-1stspi	20		N/A	us	In stop mode after wake up

Figure 2. Timing Characteristics

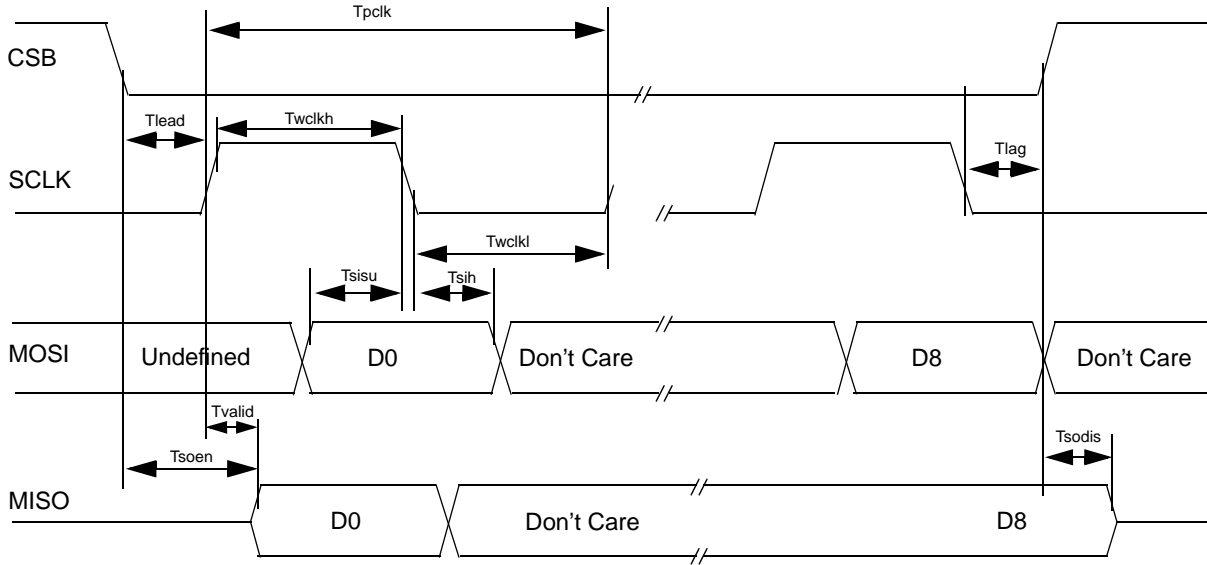

3 CAN MODULE SPECIFICATION (COMPATIBLE WITH MC33388)

ELECTRICAL RATINGS

Ratings	Symbol	Min	Typ	Max	Unit
DC Voltage On Pins Tx, Rx	V _{logic}	-0.3		V _{DD1} + 0.3	V
DC voltage at V2 (V2int)	V2int	0		5.25	V
DC Voltage On Pins CANH, CANL	V _{BUS}	-20		+27	V
Transient Voltage At Pins CANH, CANL 0 < V _{2-int} < 5.5V; V _{sup} ≥ 0; T < 500ms	V _{CANH} /V _{CANL}	-40		40	V
Transient Voltage On Pins CANH, CANL (Coupled Through 1nF Capacitor)	V _{tr}	-150		100	V
DC Voltage On Pins Rth, Rtl	V _{Rtl} , V _{rth}	-0.3		+27	V
Transient Voltage At Pins Rth, Rtl 0 < V _{2-int} < 5.5V; V _{sup} ≥ 0; T < 500ms	V _{Rth} /V _{Rtl}	-0.3		40	V
RTH, RTL Termination Resistance	R _t	500		16000	ohm

ELECTRICAL CHARACTERISTICS (V_{sup} From 5.5V to 18V, V2int from 4.75 to 5.25V and T_j from -40°C to 150°C unless otherwise noted).

Conditions	Symbol	Min	Typ	Max	Unit
------------	--------	-----	-----	-----	------

Supply current described below are the CAN module internal supply current from internal V2 (V2-int) and Vsup

Internal V2 Supply Current (CAN and SBC in Normal Mode). TX= 5V, CAN in Recessive State	I _{V2-int}	4	5.6	6.5	mA
Internal V2 Supply Current (CAN and SBC in Normal Mode). TX = 0V, No Load, CAN in Dominant State	I _{V2-int}	4.2	5.8	6.7	mA
Total supply Current (CAN in Receive Only Mode, SBC in Normal mode). Internal V2 = 5V; V _{sup} = 12V	I _{V2-int} + I _{SUP-int}		1	1.4	mA
Internal V2 Supply Current (CAN in Bus TermVbat mode) V _{sup} = 12V	I _{V2-int}		36	tbd	uA

TX Pin

High Level Input Voltage	V _{ih}	0.7*V _{2-int}		V _{2-int} +0.3V	V
Low Level Input Voltage	V _{il}	-0.3		0.3 * V _{2-int}	V
TX High Level Input Current (V _i = 4V)	I _{TX}	-100	-50	-25	uA
TX Low Level Input Current (V _i = 1V)	I _{TX}	-100	-50	-25	uA

RX Pin

High Level Output Voltage RX (I ₀ = -250μA)	V _{oh}	V _{2-int} - 0.9		V _{2-int}	V
Low Level Output Voltage (I ₀ = 1.5mA)	V _{ol}	0		0.9	V

CANH, CANL Pins

Differential Receiver, Recessive To Dominant Threshold (By Definition, V _{diff} =V _{CANH} -V _{CANL})	V _{diff1}	-3.2		-2.5	V
---	--------------------	------	--	------	---

Conditions	Symbol	Min	Typ	Max	Unit
Differential Receiver, Dominant To Recessive Threshold (Bus Failures 1, 2, 5)	V_{diff2}	-3.2		-2.5	V
CANH Recessive Output Voltage TX = 5V; $R_{(RTH)} < 4k$	V_{CANH}			0.2	V
CANL Recessive Output Voltage TX = 5V; $R_{(RTL)} < 4k$	V_{CANL}	$V_{2-int} - 0.2$			V
CANH Output Voltage, Dominant TX = 0V; $I_{CANH} = -40mA$; Normal Operating Mode	V_{CANH}	$V_{2-int} - 1.4$			V
CANL Output Voltage, Dominant TX = 0V; $I_{CANL} = 40mA$; Normal Operating Mode	V_{CANL}			1.4	V
CANH Output Current ($V_{CANH} = 0$; TX = 0)	I_{CANH}	50	75	100	mA
CANL Output Current ($V_{CANL} = 14V$; TX = 0)	I_{CANL}	50	90	130	mA
Detection Threshold For Short-circuit To Battery Voltage (Normal Mode)	V_{CANH}, V_{CANL}	7.3	7.9	8.9	V
Detection Threshold For Short-circuit To Battery Voltage (Term Vbat Mode)	V_{CANH}	$V_{BAT}/2 + 3$		$V_{BAT}/2 + 5$	V
CANH Output Current (Term Vbat Mode; $V_{CANH} = 12V$, Failure3)			5	10	uA
CANL Output Current (Term Vbat Mode; $V_{CANL} = 0V$; $V_{BAT} = 12V$, Failure 4)	I_{CANL}		0	2	uA
CANL Wake Up Voltage Threshold	$V_{wake,L}$	2.5	3	3.9	V
CANH Wake Up Voltage Threshold	$V_{wake,H}$	1.2	2	2.7	V
Wake Up Threshold Difference (Hysteresis)	$V_{wakeL} - V_{wakeH}$	0.2			V
CANH Single Ended Receiver Threshold (Failures 4, 6, 7)	$V_{SE,CANH}$	1.5	1.85	2.15	V
CANL Single Ended Receiver Threshold (Failures 3, 8)	$V_{SE,CANL}$	2.8	3.05	3.4	V
CANL Pull Up Current (Normal Mode)	$I_{CANL,pu}$	45	75	90	uA
CANH Pull Down Current (Normal Mode)	$I_{CANH,pd}$	45	75	90	uA
Receiver Differential Input Impedance CANH / CANL	R_{diff}	100		300	kohm
Differential Receiver Common Mode Voltage Range	V_{com}	-10		10	V
CANH To Ground Capacitance	C_{CANH}			50	pF
CANL To Ground Capacitance	C_{CANL}			50	pF
C_{CANL} to C_{CANH} Capacitor Difference (Absolute Value)	DC_{can}			10	pF

RTH, RTL Pins

RTL to V2-int Switch On Resistance ($I_{out} < -10mA$; Normal Operating Mode)	R_{rtl}	10	30	90	ohms
RTL to BAT Switch Series Resistance (term Vbat Mode)	R_{rtl}	8	12.5	20	kohm
RTH To Ground Switch On Resistance ($I_{out} < 10mA$; Normal Operating Mode)	R_{rth}	10	30	90	ohm

Thermal Shutdown

DEVICE DESCRIPTION

Conditions	Symbol	Min	Typ	Max	Unit
CAN Module Thermal Shutdown	T_{sd}		165		°C

AC CHARACTERISTICS (V_{SUP} From 5.5V to 18V and T_j from -40°C to 150°C unless otherwise noted)

CANL and CANH Slew Rates (10% to 90%). Rising or Falling Edges. Note 1. Recessive to Dominant state.	T_{slfr}	2		8	V/us
CANL and CANH Slew Rates (10% to 90%). Rising or Falling Edges. Note 1. Dominant to Recessive. Note 1.	T_{slrd}	2		9	V/us
Propagation Delay TX to RX Low. Note 2.	T_{onRX}		1	1.6	us
Propagation Delay TX to RX High. Note 2.	T_{offRX}		1	1.6	us
Min. Dominant Time For Wake-up On CANL or CANH (Term Vbat; $V_{SUP} = 12V$) Guaranteed by design.	T_{wake}	8	16	30	us
Failure 3 Detection Time (Normal Mode)	T_{df3}	10	30	80	us
Failure 6 Detection Time (Normal Mode)	T_{df6}	50	200	500	us
Failure 3 Recovery Time (Normal Mode)	T_{dr3}		160		us
Failure 6 Recovery Time (Normal Mode)	T_{dr6}	150	200	1000	us
Failure 4, 7, 8 Detection Time (Normal Mode)	T_{df478}	0.75	1.5	4	ms
Failure 4, 7, 8 Recovery Time (Normal Mode)	T_{dr478}	10	30	60	us
Failure 4, 7, 8 Detection Time, (Term Vbat; $V_{SUP} = 12V$)	T_{dr47}	0.8	1.2	8	ms
Failure 3 Detection Time (Term Vbat; $V_{SUP} = 12V$)	T_{dr3}		3.84		ms
Failure 3a Detection Time (Term Vbat; $V_{SUP} = 12V$)	T_{dr3a}		2.3		ms
Failure 4, 7, 8 Recovery Time (Term Vbat; $V_{SUP} = 12V$)	T_{dr47}		1.92		ms
Failure 3 Recovery Time (Term Vbat; $V_{SUP} = 12V$)	T_{dr3}		1.2		ms
Failure 3a Recovery Time (Term Vbat; $V_{SUP} = 12V$)	T_{dr3a}		1.92		ms
Edge Count Difference Between CANH and CANL for Failures 1, 2, 5 Detection (Failure bit set, Normal Mode)	E_{cdf}		3		
Edge Count Difference Between CANH And CANL For Failures 1, 2, 5 Recovery (Normal Mode)	E_{cdr}		3		
TX Permanent Dominant Timer Disable Time (Normal Mode And Failure Mode)	$t_{TX,d}$	0.75		4	ms
TX Permanent Dominant Timer Enable Time (Normal Mode And Failure Mode)	$t_{TX,e}$	10		60	us

NOTE 1: Dominant to recessive slew rate is dependant upon the bus load characteristics.

NOTE 2: AC Characteristics measured according to schematic figure 3.

DEVICE DESCRIPTION

Figure 3. Device Signal Waveforms

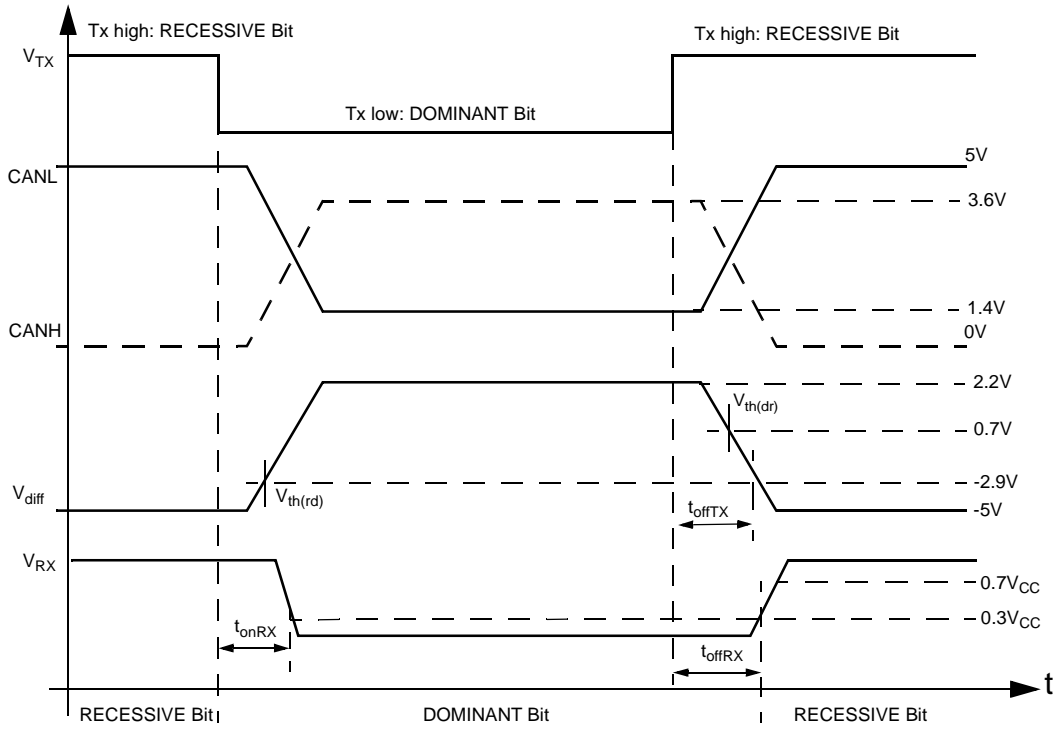
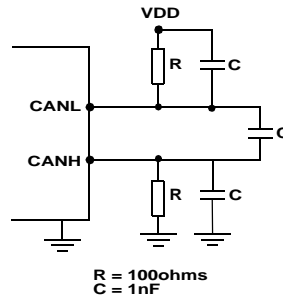

Figure 4. Test Circuit for AC Characteristics



DEVICE DESCRIPTION

4 DEVICE DESCRIPTION

Introduction:

The MC33889 is an integrated circuit dedicated to automotive applications. It includes the following functions:

- One full protected voltage regulator with 200mA total output current capability.
- Driver for external path transistor for V2 regulator function.
- Reset, programmable watchdog function
- Four operational modes
- Wake up capabilities: Forced wake up, cyclic sense and wake up inputs, CAN and SPI
- Can low speed fault tolerant physical interface, compatible with Motorola MC33388D.

4.1 Device Supply

The device is supplied from the battery line through the Vsup pin. An external diode is required to protect against negative transients and reverse battery. It can operate from 4.5V and under the jump start condition at 27V DC. This pin sustains standard automotive voltage conditions such as load dump at 40V. When Vsup falls below 3V typical the MC33889 detects it and store the information into the SPI register, in a bit called "BATFAIL". This detection is available in all operation modes.

4.2 Vdd1 Voltage Regulator

Vdd1 Regulator is a 5V output voltage with total current capability of 200mA. It includes a voltage monitoring circuitry associated with a reset function. The Vdd1 regulator is fully protected against over current, short-circuit and has over temperature detection warning flags and shutdown with hysteresis.

4.3 V2 regulator

V2 Regulator circuitry is designed to drive an external path transistor in order to increase output current flexibility. Two pins are used: V2 and V2 ctrl. Output voltage is 5V and is realized by a tracking function of the Vdd1 regulator. Recommended ballast transistor is MJD32C. Other transistor might be used, however depending upon PNP gain an external resistor capacitor network might be connected between emitter and base of PNP. The use of external ballast is optional (refer to simplified typical application). State of V2 is reported into IOR register (if V2 is below 4.5V typical in case of over load or short circuit).

4.4 HS1 Vbat Switch Output

HS1 output is a 2 ohms typical switch from Vsup pin. It allows the supply of external switches and their associated pull up or pull down circuitry, in conjunction with the wake up input pins for example. Output current is limited to 200mA and HS1 is protected against short-circuit and has an over temperature shutdown (reported in IOR register). HS1 output is controlled from the internal register and SPI. It can be activated at regular intervals in sleep mode thanks to internal timer. It can also be permanently turned on in normal or stand-by modes to drive external loads such as relays or supply peripheral components. In case of inductive load drive external clamp circuitry must be added.

4.5 Functional Modes

The device has four modes of operation, stand-by, normal, stop and sleep modes. All modes are controlled by the SPI. An additional temporary mode called "normal request mode" is automatically accessed by the device (refer to state machine) after wake up events. Special mode and configuration are possible for software application debug and flash memory programming.

4.5.1 Normal mode:

In this mode both regulators are ON and this corresponds to the normal application operation. All functions are available in this mode (watchdog, wake up input reading through SPI, HS1 activation, CAN communication). The software watchdog is running and must be periodically cleared through SPI.

4.5.2 Standby mode:

Only the regulator 1 is ON. Regulator 2 is turned OFF by disabling the V2 ctrl pin. The CAN cell is not available, as powered from V2, other functions are available: wake up input reading through SPI, HS1 activation. The watchdog is running.

4.5.3 Sleep mode:

Regulators 1 and 2 are OFF. In this mode, the MCU is not powered. In this mode, the device can be awakened internally by cyclic sense via the wake up inputs pins and HS1 output, from the forced wake function, the CAN physical interface, and SPI (CSB pin).

4.5.4 Stop mode

Regulator 2 is turned OFF by disabling the V2 ctrl pin. The regulator 1 is activated in a special low power mode which allow to deliver 2 mA. The objective is to maintain the MCU of the application supplied while it is turned into power saving condition (i.e stop or wait mode).

Stop mode is entered through SPI. Stop mode is dedicated to power the Microcontroller when it is in low power mode (stop, pseudo stop, wait etc.). In these mode the MCU supply current is less than 1mA. The MCU can restart its software application very quickly, without the complete power up and reset sequence.

When the application is in stop mode (both MCU and SBC), the application can wake up from the SBC side (ex cyclic sense, forced wake up, CAN message, wake up inputs) or the MCU side (key wake up etc.).

When Stop mode is selected by SPI, stop mode becomes active 20us after end of SPI message. The "go to stop" instruction must be the last instruction executed by the MCU before going to low power mode.

DEVICE DESCRIPTION

In stop mode the Software watchdog can be “running” or “not running” depending upon selection by SPI. Refer to SPI description, RCR register bit WDSTOP. If W/D is enabled the SBC must be wake up before W/D time expired, otherwise a reset is generated. In stop mode, SBC wake up capability are identical as in sleep mode.

4.5.4.1 Stop mode: wake up from SBC side, INT pin activation:

When application is in stop mode, it can wake up from the SBC side. When a wake up is detected by the SBC (ex CAN, Wake up input, forced wake up etc.) the SBC turns itself into Normal request mode and activated the Vdd1 main regulator. When the main regulator is fully active, then the wake up is signalled to the MCU through the INT pin. INT pin is pulled low for 10us and then returns high. Wake up event can be read through the SPI registers.

4.5.4.2 Stop mode: wake up from MCU side:

When application is in stop mode, the wake up event may come to the MCU. In this case the MCU has to signal to the SBC that it has to go into Normal mode in order for the Vdd1 regulator to be able to deliver full current capability. This is done by a low to high transition of the CSB pin. CSB pin low to high activation has to be done as soon as possible after the MCU. The SBC generates a pulse at INTB pin. Alternatively the L0 and L1 inputs can also be used as wake up from stop mode.

4.5.4.3 Stop mode current monitoring

If the current in stop mode exceed the Idd1s-wu threshold, the SBC jumps into Normal request mode, activated the Vdd1 main regulator and generate and interrupt to the MCU. This interrupt is not maskable and not bit are set into the INT register.

4.5.4.4 Software watchdog in stop mode:

If watchdog is enabled (register MCR, bit WDSTOP set), the MCU has to wake up independently of the SBC before the end of the SBC watchdog time. In order to do this the MCU has to signal the wake to the SBC through the SPI wake up (CSB pin low to high transition to activated SPI wake up). Then the SBC wakes up and jump into the normal request mode. MCU has to configure the SBC to go to either normal or standby mode. The MCU can then decide to go back again to stop mode.

If no MCU wakes up occurs within the watchdog timing, the SBC will activate the reset pin and jump into the normal request mode. The MCU can then be initialized.

4.5.5 Normal request mode:

This is a temporary mode automatically accessed by the device after a wake up event from sleep or stop mode or after device power up. In this mode the Vdd1 regulator is ON, V2 is off, the reset pin is high. As soon as the device enters the normal request mode an internal 350ms timer is started. During these 350ms the micro controller of the application must addressed the SBC via SPI and configure the watchdog register (TIM1 register). This is the condition for the SBC to leave the Normal request Mode and enter the Normal mode and to set the watchdog timer according to configuration done during the Normal Request mode.

“BATFAIL flag” is a bit which is triggered when Vsup is below 3V. This bit is set into the MCR register. It is reset by MCR register read.

4.6 Internal Clock

The device has an internal clock used to generate all timings (reset, watchdog, cyclic wake up, filtering time etc....).

4.7 Reset pin

A reset output is available in order to reset the microcontroller. The reset cause are:

- Vdd1 falling out of range: if Vdd1 fall below the reset threshold (parameter Rst-th), the reset pin is pull low until Vdd1 return to nominal voltage.

- Power on reset: at device power on or at device wake up from sleep mode, the reset is maintained low until Vdd1 is within its operation range.

- Watchdog time out: if the watchdog is not cleared the SBC will pull the reset pin low for the duration of the reset duration time (parameter: reset-dur).

For debug purposes at 25°C, reset pin can be shorted to 5V.

4.8 Software watchdog (selectable window or time out watchdog)

Software watchdog is used in the SBC normal and stand-by modes for the MCU monitoring. The watchdog can be either window or time out. This is selectable by SPI (register TIM, bit WDW). Default is window watchdog. The period for the watchdog is selectable by SPI from 5 to 350ms (register TIM, bits WDT0 and WDT1). When the window watchdog is selected, the closed window is the first half of the selected period, and the open window is the second half of the period. The watchdog can only be cleared within the open window time. An attempt to clear the watchdog in the closed window will generate a reset. Watchdog is cleared through SPI by addressing the TIM register.

Refer to” table for reset pin operations operation in mode 2.

4.9 Wake Up capabilities

Several wake-up capabilities are available for the device when it is in sleep or stop mode. When a wake up has occurred, the wake up event is stored into the WUR or CAN registers. The MCU can then access to the wake up source. The wake up options are selectable trough SPI while the device is in normal or standby mode and prior to go to enter low power mode (sleep or stop mode).

4.9.1 Wake up from wake up inputs (L0, L1) without cyclic sense:

The wake up lines are dedicated to sense external switches state and if changes occur to wake up the MCU (In sleep or stop modes). The wake up pins are able to handle 40V DC. The internal threshold is 3V typical and these inputs can be used as input port expander. The wake up inputs state can be read through SPI (register WUR). L0 has a lower threshold than L1 in order to allow connection and wake up from a digital output such as a CAN physical interface for instance.

4.9.2 Cyclic sense wake up (Cyclic sense timer and wake up inputs L0, L1)

The SBC can wake up upon state change of one of the wake up input lines (L0, L1) while the external pull up or pull down resistor of the switches associated to the wake up input lines are biased with HS1 Vsup switch. The HS1 switch is activated in sleep or stop mode from an internal timer. Cyclic sense and Forced wake up are exclusive. If Cyclic Sense is enabled the forced wake up can not be enabled.

4.9.3 Forced wake up

The SBC can wake up automatically after a pre determined time spent in sleep or stop mode. Forced wake up is enabled by setting bit FWU in LPC register. Cyclic sense and Forced wake up are exclusive. If Forced wake up is enabled the Cyclic Sense can not be enabled.

4.9.4 CAN wake up

The device can wake up from a CAN message. CAN wake up cannot be disabled.

4.9.5 SPI wake up

The device can wake up by the CSB pin in sleep or stop mode. Wake up is detected by CSB pin transition from low to high level. In stop mode this correspond to the condition where MCU and SBC are both in Stop mode and when the application wake up events come through the MCU.

4.9.6 System power up

At power up the device automatically wakes up.

4.10 SPI

The complete device control as well as the status report is done through a 8 bits SPI interface. Refer to SPI paragraph.

4.11 CAN

The device incorporates a low speed fault tolerant CAN physical interface. Speed rate is up to 125kBauds. Its electrical parameters for the CANL, CANH, Rtl, Rth Rx and Tx pins are compatible with the MC33388D. The state of the CAN interface is programmable through SPI.

4.12 Device power up, SBC wake up

After device or system power up or a wake up from sleep mode, the SBC enters into "reset mode" then into "normal request mode".

4.13 Battery fall early warning:

This function provides an Interrupt when the Vsup voltage is below 6.1V typical. This interrupt is maskable. An hysteresis is included. Operation is only in Normal and Standby modes. Vbat low state reported in IOR register.

4.14 Package and thermal consideration

The device is proposed in a standard surface mount SO28 package. In order to improve the thermal performances of the SO28 package, 8 pins are internally connected to the lead frame and are used for heat transfer to the printed circuit board.

4.15 Table 1: Reset and Wdogb operation

Figure below shows the reset and watchdog output operation. Reset is active at device power up and wake up. Reset is activated in case of Vdd1 fall or watchdog not triggered. Wdogb output is active low as soon as reset goes low and stays low as long as the watchdog is not properly re-activated by SPI.

Figure 5. Reset and Wdogb function diagram

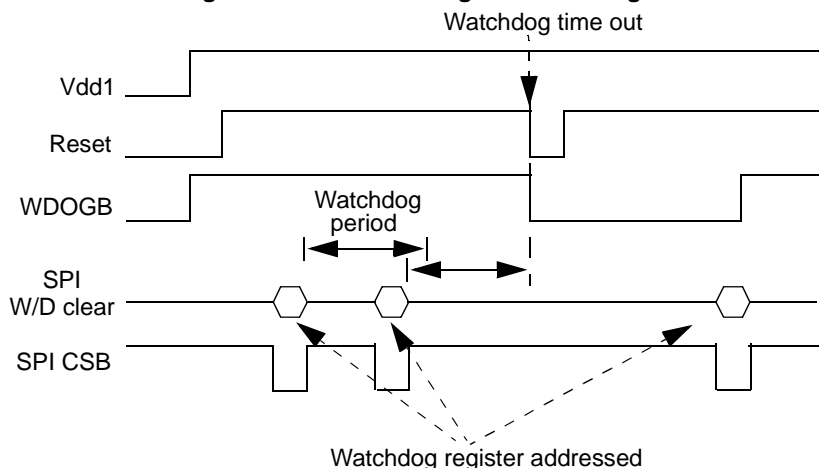

The Wdogb output pin is a push pull structure than can drive external component of the application in order for instance to signal MCU wrong operation. Even if it is internally turned on (low state) the reset pins can be forced to 5V at 25°C only, thanks to its internal limited current drive capability. Wdogb stays low until the Watchdog register is properly addressed through SPI.

4.16 Debug mode Application hardware and software debug with the SBC.

When the SBC is mounted on the same printed circuit board as the micro controller it supplies, both application software and SBC dedicated routine must be debugged. Following features allow the user to debug the software by allowing the possibility to disable the SBC internal software watchdog timer.

4.16.1 Device power up, reset pin connected to Vdd1

At SBC power up, the Vdd1 voltage is provided, but if no SPI communication occurs to configure the device, a reset occurs every 350ms. In order to allow software debug and avoid MCU reset the Reset pin can be connected directly to Vdd1 by a jumper.

4.16.2 Debug modes with software watchdog disabled though SPI (Normal Debug, Standby Debug and Stop Debug)

The software watchdog can be disabled through SPI. In order to avoid unwanted watchdog disable and to limit the risk of disabling the watchdog during SBC normal operation the watchdog disable has to be done with the following sequence:

- Step 1) Power down the SBC
- Step 2) Power up the SBC (The BATFAIL bit is set, and the SBC enters normal request mode)
- Step 3) Write to TIM1 register to allow SBC to enter Normal mode
- Step 4) Write to MCR register with data 0000 (this enables the debug mode). (Complete SPI byte: 000 1 0000)
- Step 5) Write to MCR register normal debug (0001 x101), standby debug (0001 x110) or Stop debug (0001 x111)

While in debug mode, the SBC can be used without having to clear the W/D on a regular basis to facilitate software and hardware debug.

- Step 6) To leave the debug mode, write 0000 to MCR register.
- To avoid entering debug mode after a power up, first read BATFAIL bit (MCR read) and write 0000 into MCR.
The graph below illustrates the debug mode entering.

Figure 6. Debug mode enter

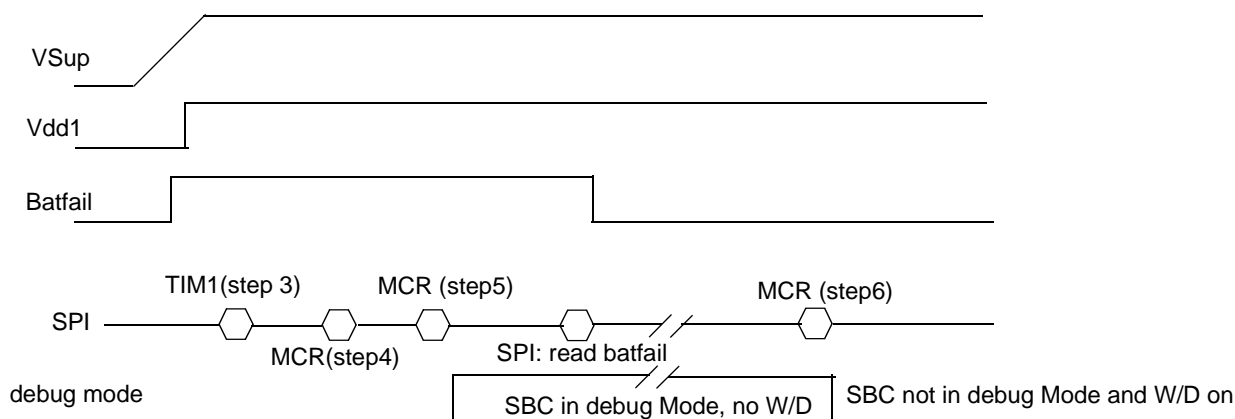

4.16.3 MCU flash programming configuration

In order to allow the possibility to download software into the application memory (MCU EEPROM or Flash) the SBC allows the following capabilities: The Vdd1 can be forced by an external power supply to 5V and the reset and Wdogb outputs by

external signal sources to zero or 5V and this without damage. This allow for instance to supply the complete application board by external power supply and to apply the correct signal to reset pins.

4.17 Gnd Shift Detection

4.17.1 General

When normally working in two-wire operating mode, the CAN transmission can afford some ground shift between different nodes without trouble. Nevertheless, in case of bus failure, the transceiver switches to single-wire operation, therefore working with less noise margin. The affordable ground shift is decreased in this case.

The SBC provides a ground shift detection for diagnosis purpose. Four ground shift levels are selectable and the detection is stored in the IOR register which is accessible via the SPI.

4.17.2 Detection Principle

The gnd shift to detect is selected via the SPI out of 4 different values (-0.5V, -1V, -1.5V, -2V). At each TX falling edge (end of recessive state) CANH voltage is sensed. If it is detected to be below the selected gnd shift threshold, the bit SHIFT is set at 1 in IOR register. No filter is implemented. Required filtering for reliable detection should be done by software (e.g. several trials).

5 TABLE OF OPERATION

The table below describe the SBC operation modes.

mode	Voltage Regulator HS1 switch	Wake up capabilities (if enabled)	Reset pin	INT	Software Watchdog	CAN cell
Normal Request	Vdd1: ON V2: OFF HS1: OFF		Low for 1ms, then high			term Vbat
Normal	Vdd1: ON V2: ON HS1 controllable		Normally high. Active low if W/D or Vdd1 under voltage occur	If enabled, signal failure (Vdd pre warning temp, CAN, HS1)	Running	Term Vbat Tx/Rx Rec only
Standby	Vdd1: ON V2: OFF HS1 controllable		Normally high. Active low if W/D or Vdd1 under voltage occur	If enabled, signal failure (Vdd temp, HS1)	Running	Term Vbat Tx/Rx Rec only
Stop	Vdd1: ON (limited current capability) V2: OFF HS1: OFF or cyclic	CAN (always enable) SPI and L0,L1 Cyclic sense or Forced Wake up	Normally high. Active low if W/D or Vdd1 under voltage occur	Signal SBC wake up (not maskable)	- Running if enabled - Not Running if disabled	Term Vbat.
Sleep	Vdd1: OFF V2: OFF HS1 OFF or cyclic	CAN (always enable) SPI and L0,L1 Cyclic sense Forced Wake up	Low	Not active	No Running	Term Vbat.

Tableau 1 : table of operation

SIMPLIFIED STATE MACHINE

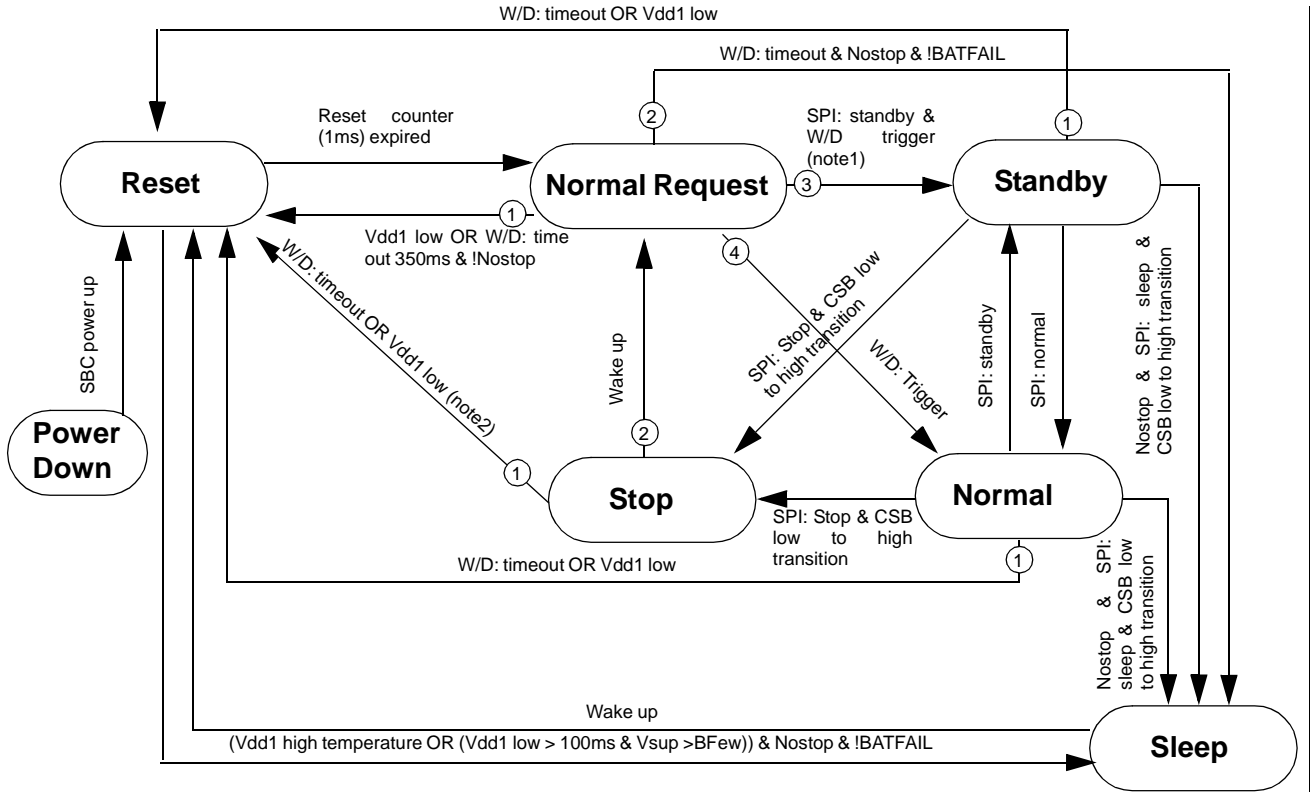

① ② ③ ④ denotes priority

State machine description:

- "Nostop" means Nostop bit = 1
- "! Nostop" means Nostop bit = 0
- "BATFAIL" means Batfail bit = 1
- "! BATFAIL" means Batfail bit = 0
- "Vdd1 over temperature" means Vdd1 thermal shutdown occurs
- "Vdd1 low" means Vdd1 below reset threshold
- "Vdd1 low > 100ms" means Vdd1 below reset threshold for more than 100ms

- "W/D: time out" means TIM1 register not written before W/D time out period expired, or W/D written in incorrect time window if window W/D selected (except stop mode). In normal request mode time out is 355ms p2.2 (350ms p3)ms.
- "SPI: Sleep" means SPI write command to MCR register, data sleep
- "SPI: Stop" means SPI write command to MCR register, data stop
- "SPI: Normal" means SPI write command to MCR register, data normal
- "SPI: Standby" means SPI write command to MCR register, data standby

"W/D: Trigger" means TIM1 register write operation.
Vsup>BFew means Vsup > Battery Fall Early Warning (6.1V typical)

Note 1: these 2 SPI commands must be send in this sequence and consecutively.
Note 2: if W/D activated

Behavior at SBC power up

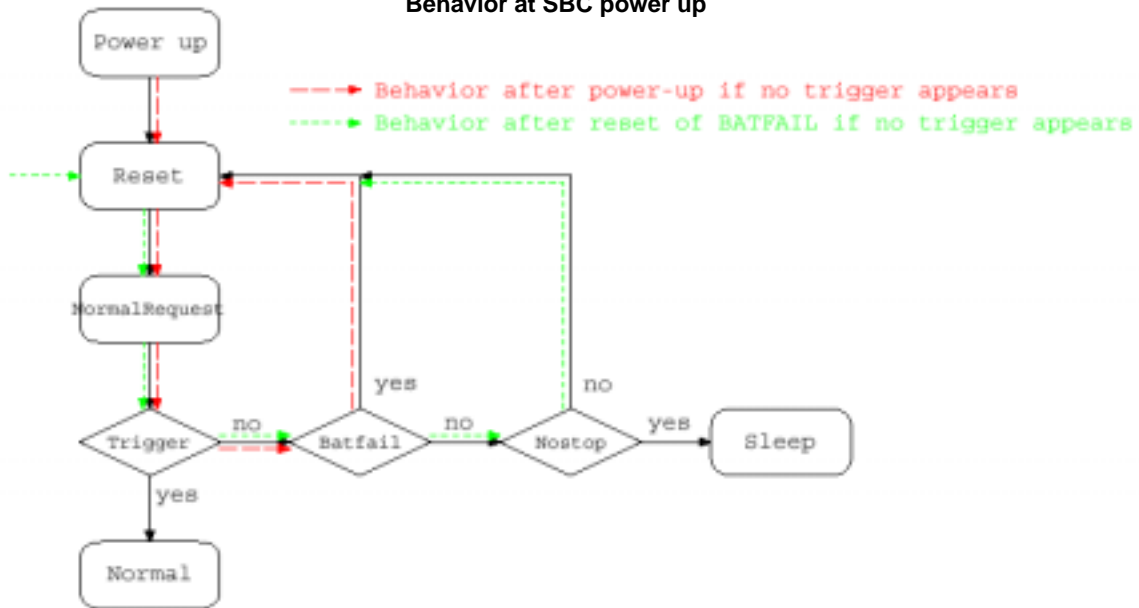

6 TYPICAL APPLICATIONS

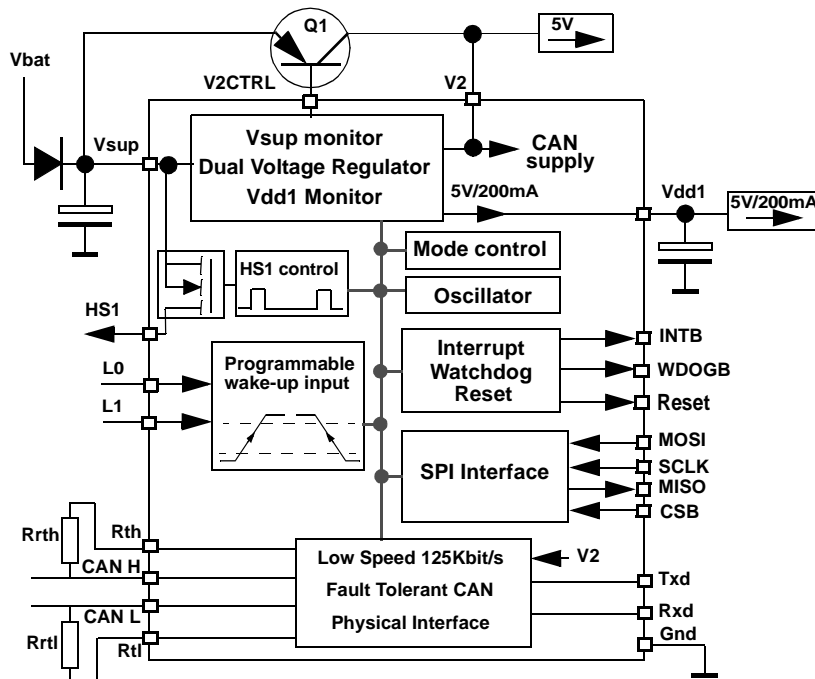

Fig 1: Simplified typical application with ballast transistor

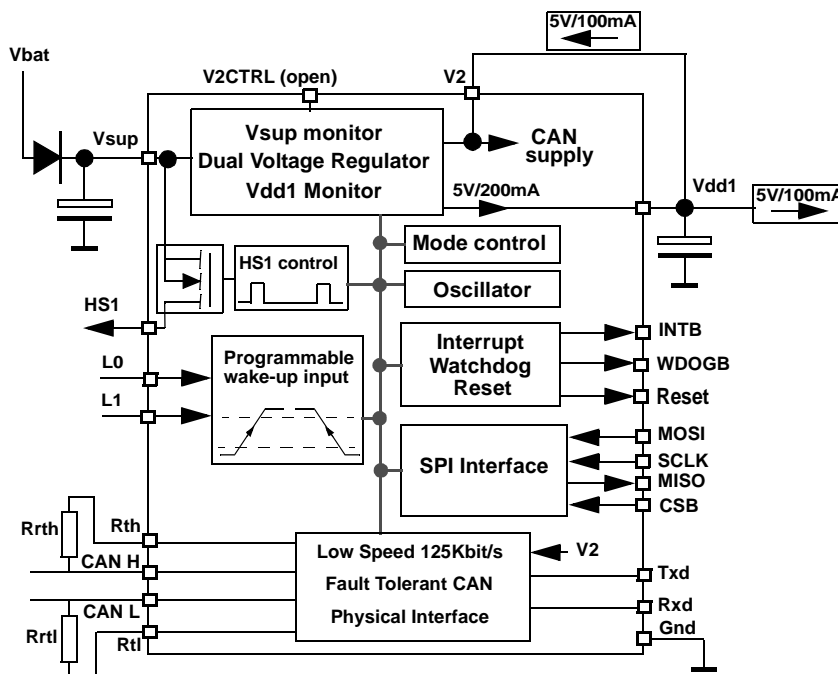
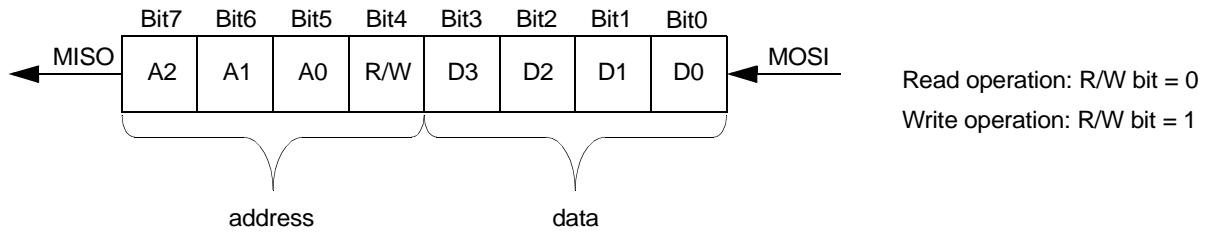

Fig 2: Simplified typical application without ballast transistor

7 SPI INTERFACE

7.1 Data format description



The SPI is a 8 bit SPI. First 3 bits are used to identify the internal SBC register address, bit 4 is a read/write bit. The last 4 bits are data send from MCU to SBC or read back from SBC to MCU.

During write operation state of MISO has no signification.

During read operation only the last 4 bits at MISO have a meaning (content of the accessed register)

Following tables describe the SPI register list, and register bit meaning.

Registers "reset value" is also described, as well as the "reset condition". reset condition is the condition which cause the bit to be set at the "reset value".

Possible reset condition are:

Power On Reset: POR

SBC mode transition:

- NR2R - Normal Request to Reset mode
- NR2N - Normal Request to Normal mode
- N2R - Normal to Reset mode
- STB2R - Standby to Reset mode
- STO2R - Stop to Reset mode

SBC mode:

RESET - SBC in Reset mode

List of Registers

Name	Adress	Description	Comment and usage
MCR	\$ 0 0 0	Mode control register	Write: Control of normal, standby, sleep, and stop modes Read: BATFAIL flag and other status bits and flags
RCR	\$ 0 0 1	Reset control register	Write: Configuration of reset voltage level, WD in stop mode, low power mode selection Read: CAN wake up event, Tx permanent dominant
CAN	\$ 0 1 0	CAN control register	Write: CAN module control: Tx/Rx, Rec only, term Vbat, Normal and extended modes, filter at L0 input. Read: CAN failure status bits
IOR	\$ 0 1 1	I/O control register	Write: HS1 (high side switch) control in normal and standby mode. Gnd shift register level selection Read: HS1 over temp bit, SHIFT bit (gnd shift above selection), Vsup below 6.1V, V2 below 4V
WUR	\$ 1 0 0	Wake up input register	Write: Control of wake up input polarity Read: Wake up input, and real time Lx input state
TIM	\$ 1 0 1	Timing register	Write: TIM1, Watchdog timing control, window or Timeout mode. Write: TIM2, Cyclic sense and force wake up timing selection
LPC	\$ 1 1 0	Low power mode control register	Write: HS1 periodic activation in sleep and stop modes Force wake up control
INTR	\$ 1 1 1	Interrupt register	Write: Interrupt source configuration Read: INT source

Table 7-1.

7.2 Register description

7.2.1 MCR Register

MCR		D3	D2	D1	D0
\$000b	W		MCTR2	MCTR1	MCTR0
	R	BATFAIL	VDDTEMP	GFAIL	WDRST
Reset		0	0	0	0
Reset condition			POR, RESET	POR, RESET	POR, RESET

Table 7-2.

Control bits

MCTR2	MCTR1	MCTR0	SBC mode	Description
0	0	0	Enter/leave debug mode	To enter debug mode, SBC must be in Normal or Standby mode and BATFAIL ⁽¹⁾ must be still at 1. To leave debug mode, BATFAIL must be at 0.
0	0	1	Normal	
0	1	0	Standby	
0	1	1	Stop, watchdog off ⁽²⁾	
0	1	1	Stop, watchdog on ⁽²⁾	
1	0	0	Sleep ⁽³⁾	
1	0	1	Normal	No watchdog running, debug mode
1	1	0	Standby	
1	1	1	Stop	

(1): Bit BATFAIL cannot be set by SPI. BATFAIL is set when Vsup falls below 3V.

(2): Watchdog ON or OFF depends upon RCR register bit D3.

(3): Before entering sleep mode, bit NOSTOP in RCR register must be previously set to 1.

Status bits

Status bit	Description
GFAIL	Logic OR of CAN failure, HS1 failure, V2LOW
BATFAIL	Battery fail flag (Vsup<3V)
VDDTEMP	Temperature pre-warning on VDD (latched)
WDRST	Watchdog reset occurred

7.2.2 RCR register

RCR		D3	D2	D1	D0
\$001b	W	WDSTOP	NOSTOP		RSTTH
	R			TXFAILURE	CANWU
Reset		1	0		0
Reset condition		POR, RESET	POR, NR2N		POR

Table 7-3.

Control bits

Status bit	Bit value	Description
WDSTOP	0	No watchdog in stop mode
	1	Watchdog runs in stop mode
NOSTOP	0	Stop mode is default low power mode
	1	Sleep mode is default low power mode
RSTTH	0	Reset threshold 1 selected (typ 4.6V)
	1	Reset threshold 2 selected (typ 4.2V)
CANWU	1	Wake from CAN
TXFAILURE	1	Tx permanent dominant (CAN)

7.2.3 CAN register

Some description.

CAN		D3	D2	D1	D0
\$010b	W	FDIS	CEXT	CCTR1	CCTR0
	R	CS3	CS2	CS1	CS0
Reset		0	0	0	0
Reset condition		POR, CAN	POR, CAN	POR, CAN	POR, CAN

Table 7-4.

Fault tolerant CAN transceiver standard modes

The CAN transceiver standard mode can be programmed by setting CEXT to 0. The transceiver cell will then be behave as known from MC33388.

CEXT	CCTR1	CCTR0	Mode
0	0	0	TermVBAT
0	0	1	
0	1	0	RxOnly
0	1	1	RxTx

Table 7-5.

Fault tolerant CAN transceiver extended modes

By setting CEXT to 1 the transceiver cell supports sub bus communication.

CEXT	CCTR1	CCTR0	Mode
1	0	0	TermVBAT
1	0	1	TermVDD
1	1	0	RxOnly
1	1	1	RxTx

Table 7-6.

FDIS	L0 wake input filter (20us typical)
0	Enable (LO wake threshold selectable by WUR register)
1	Disable (L0 wake up threshold is low level only, no matter D0 and D1 bits set in WUR register).

note: if DFIS bit is set to 1, WUR register must be read before going into sleep or stop mode in order to clear the wake up flag. During read out L0 must be at high level and should stay high when entering sleep or stop.

Status bits

CS3	CS2	CS1	CS0	Bus failure #	Description	
0	0	0	0		no failure	
0	0	0	1	1	CANH open wire	
0	1	0	1	5	CANH short circuit to	ground
0	1	1	0	8, 3a		VDD
0	1	1	1	3		VBAT
1	0	0	1	2	CANL open wire	
1	1	0	1	4, 7	CANL short circuit to	ground / CANL
1	1	1	0	9		VDD
1	1	1	1	6		VBAT

comments:

CS2 bit at 0 = open failure. CS2 bit at 1 = short failure.

(CS3 bit at 0 and (CS1 = 1 or CS2 =1)) = CANH failure. CS3 bit at 1 = CANL failure.

CS1 and CS0 bits: short type failure coding (gnd, Vdd or Vbat).

In case of multiple failures, the last failure is reported.

7.2.4 IOR register

Some description.

IOR		D3	D2	D1	D0
\$011b	W		HS1ON	GSLR1	GSLR0
	R	SHIFT	HS1OT	V2LOW	VSUPLOW
Reset			0	0	0
Reset condition			POR, RESET	POR, RESET	POR, RESET

Table 7-7.

Control bits

HS1ON	HS1
0	HS1 switch turn OFF
1	HS1 switch turn ON

Table 7-8.

GSLR1	GSLR0	typical gnd shift comparator level
0	0	-0.5 V
0	1	-1 V
1	0	-1.5 V
1	1	-2 V

Table 7-9. gnd shift selection

SHIFT	state
0	Gnd shift value is lower GSLR1 and GSLR2 selection
1	Gnd shift value is higher GSLR1 and GSLR2 selection

Status bits

Status bit	Description
HS1OT (*)	High side 1 over temperature
SHIFT	gnd shift level selected by GSLR1 and GSLR2 bits is reached
V2LOW	V2 below 4V typical
VSUPLOW	Vsup below 6.1V typical

(*) Once the HS1 switch has been turned off because of over temperature, it can be turned on again by setting the appropriate control bit to "1".

7.2.5 WUR register

The local wake-up inputs L0 and L1 can be used in both normal and standby mode as port expander and for waking up the SBC in sleep or stop mode.

WUR		D3	D2	D1	D0
\$100b	W	LCTR3	LCTR2	LCTR1	LCTR0
	R	L1WU _b	L1WU _a	L0WU _b	L0WU _a
Reset		1	1	1	1
Reset condition		POR, NR2R, N2R, STB2R, STO2R			

Table 7-10.

Control bits:

LCTR3	LCTR2	LCTR1	LCTR0	L0 configuration	L1 configuration
X	X	0	0	inputs disabled	
X	X	0	1	high level sensitive	
X	X	1	0	low level sensitive	
X	X	1	1	both level sensitive	
0	0	X	X		inputs disabled
0	1	X	X		high level sensitive
1	0	X	X		low level sensitive
1	1	X	X		both level sensitive

Table 7-11.

Status bits:

LOWUb	LOWUa	FDIS bit in CAN register	Description
0	0	0	No wake up occurred at L0 (sleep or stop mode). Low level state on L0 (standby or normal mode)
1	1	0	Wake up occurred at L0 (sleep or stop mode). High level state on L0 (standby or normal mode)
0	1	1	Wake up occurred at L0 (sleep or stop mode with L0 filter disable). WUR must be set to xx00 before sleep or stop mode.

L1WUb	L1WUa	Description
0	0	No wake up occurred at L1 (sleep or stop mode). Low level state on L1 (standby or normal mode)
1	1	Wake up occurred at L1 (sleep or stop mode). High level state on L1 (standby or normal mode)

7.2.6 TIM registers

Description: This register is splitted into 2 sub registers, TIM1 and TIM2.

TIM1 controls the watchdog timing selection as well as the window or time out option. TIM1 is selected when bit D3 is 0.

TIM2 is used to define the timing for the cyclic sense and forced wake up function. TIM2 is selected when bit D3 is 1.

No read operation is allowed for registers TIM1 and TIM2

7.2.7 TIM register

Description.

TIM1		D3	D2	D1	D0
\$101b	W	0	WDW	WDT1	WDT0
	R				

Table 7-12.

TIM1		D3	D2	D1	D0
Reset			0	0	0
Reset condition			POR, RESET	POR, RESET	POR, RESET

Table 7-12.

Description

WDW	WDT1	WDT0	Watchdog timing [ms]	
0	0	0	10	no window watchdog
0	0	1	50	
0	1	0	100	
0	1	1	350	
1	0	0	10	window watchdog enabled (window length is half the watchdog timing)
1	0	1	50	
1	1	0	100	
1	1	1	350	

Table 7-13.

jWatchdog operation (window and time out)

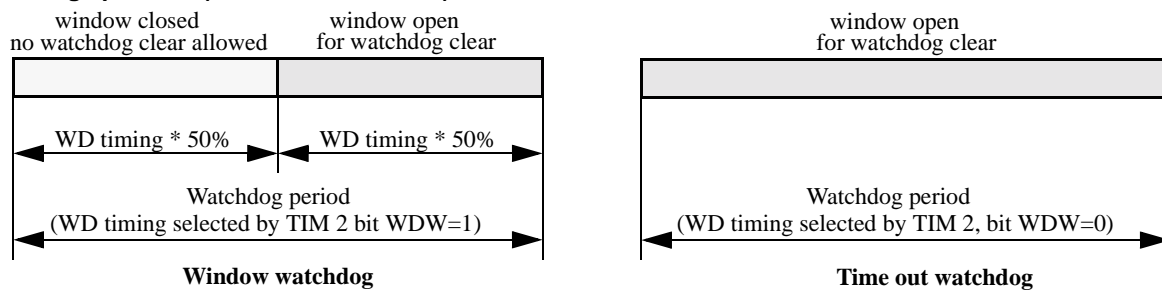

7.2.8 TIM2 register

The purpose of TIM2 register is to select an appropriate timing for sensing the wake-up circuitry or cyclically supplying devices by switching on or off HS1

TIM2		D3	D2	D1	D0
\$101b	W	1	CSP2	CSP1	CSP0
	R				
Reset			0	0	0
Reset condition			POR, RESET	POR, RESET	POR, RESET

Table 7-14.

CSP2	CSP1	CSP0	Cyclic sense timing [ms]
0	0	0	5
0	0	1	10
0	1	0	20

Table 7-15.

CSP2	CSP1	CSP0	Cyclic sense timing [ms]
0	1	1	40
1	0	0	75
1	0	1	100
1	1	0	200
1	1	1	400

Table 7-15.

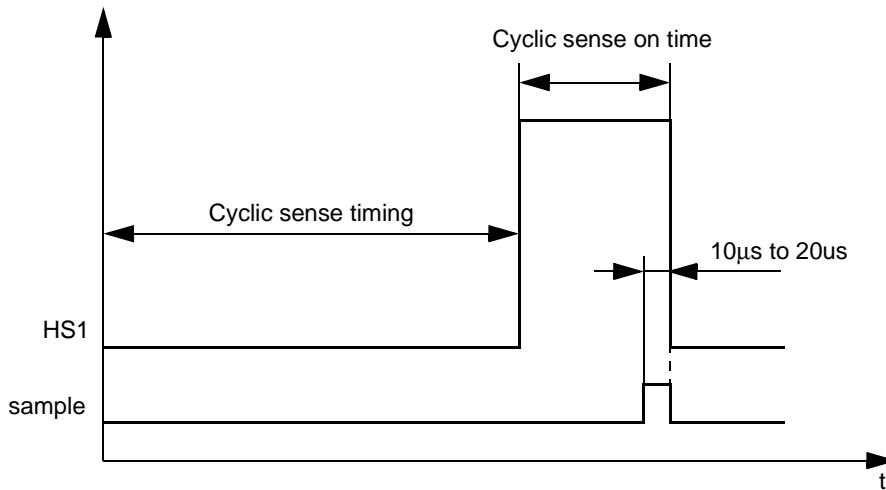

7.2.9 LPC register

Description: This register controls:

- The state of HS1 in stop and sleep mode (HS1 permanently off or HS1 cyclic)
- Enable or Disable the forced wake up function (SBC automatic wake up after time spend in sleep or stop mode, time defined by TIM2 register)
- Enable or disable the sense of the wake up inputs (Lx) at sampling point of the cyclic sense period (LX2HS1 bit).

LPC		D3	D2	D1	D0
\$110b	W	LX2HS1	FWU	IDDS	HS1AUTO
	R				
Reset		0	0	0	0
Reset condition		POR, NR2R, N2R, STB2R, STO2R	POR, NR2R, N2R, STB2R, STO2R	POR, NR2R, N2R, STB2R, STO2R	POR, NR2R, N2R, STB2R, STO2R

Table 7-16.

LX2HS ₁	HS1AUTO	Wake-up inputs supplied by HS1	Autotiming HS1
X	0		off
X	1		on, HS1 cyclic, period defined in TIM2 register
0	X	no	
1	X	yes, Lx inputs sensed at sampling point	

Table 7-17.

Bit	Description
FWU	If this bit is set, and the SBC is turned into sleep or stop mode, the SBC wakes up after the time selected in the TIM2 register
IDDS	Bit = 0: Idds-wu1 selected (lowest value, typ 3.5mA) Bit = 1: Idds-wu2 selected (highest value, typ 14mA)

7.2.10 INTR register

INTR		D3	D2	D1	D0
\$111b	W	VSUPLOW	HS1OT-V2LOW	VDDTEMP	CANF
	R	VSUPLOW	HS1OT	VDDTEMP	CANF
Reset		0	0	0	0
Reset condition		POR, RESET	POR, RESET	POR, RESET	POR, RESET

Table 7-18.

Control bits:

Control bit	Description
CANF	Mask bit for CAN failures (OR of any CAN failure)
VDDTEMP	Mask bit for VDD medium temperature
HS1OT-V2LOW	Mask bit for HS1 over temperature OR V2 below 4V
VSUPLOW	Mask bit for sup below 6.1V

When the mask bit has been set, INTB pin goes low if the appropriate condition occurs.

Status bits:

Status bit	Description
CANF	CAN failure
VDDTEMP	VDD medium temperature
HS1OT	HS1 over temperature
VSUPLOW	Vsup below 6.1V typical

Notes:

If HS1OT-V2LOW interrupt is only selected (only bit D2 set in INTR register), reading INTR register bit D2 leads to two possibilities:

- Bit D2 = 1: INT source is HS1OT
- Bit D2 = 0: INT source is V2LOW.

Upon a wake up condition from stop mode due to over current detection (Idd1s-wu1 or Idd1s-wu2), an INT pulse is generated, however INTR register contain remains at 0000 (not bit set into the INTR register).

CASE OUTLINE

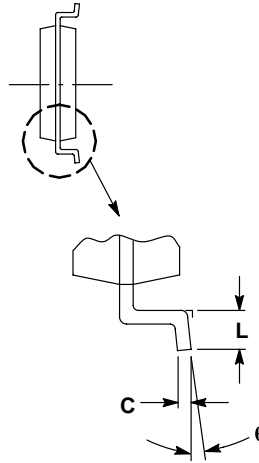
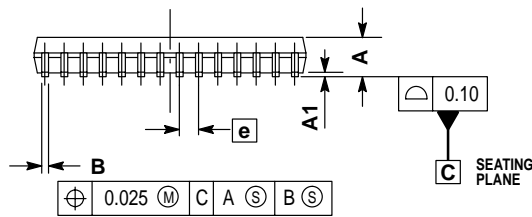
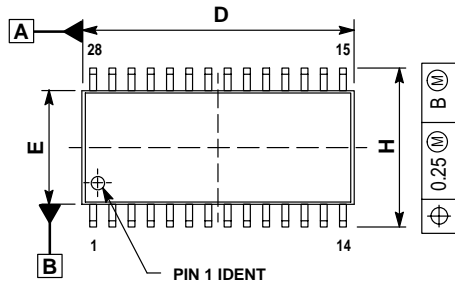

NOTES:

1. DIMENSIONS ARE IN MILLIMETERS.
2. INTERPRET DIMENSIONS AND TOLERANCES PER ASME Y14.5M, 1994.
3. DIMENSIONS D AND E DO NOT INCLUDE MOLD PROTRUSIONS.
4. MAXIMUM MOLD PROTRUSION 0.015 PER SIDE.
5. DIMENSION B DOES NOT INCLUDE DAMBAR PROTRUSION. ALLOWABLE DAMBAR PROTRUSION SHALL BE 0.13 TOTAL IN EXCESS OF B DIMENSION AT MAXIMUM MATERIAL CONDITION.

DIM	MILLIMETERS	
	MIN	MAX
A	2.35	2.65
A1	0.13	0.29
B	0.35	0.49
C	0.23	0.32
D	17.80	18.05
E	7.40	7.60
e	1.27 BSC	
H	10.05	10.55
L	0.41	0.90
θ	0°	8°

CASE 751F-05
ISSUE F

Motorola reserves the right to make changes without further notice to any products herein. Motorola makes no warranty, representation or guarantee regarding the suitability of its products for any particular purpose, nor does Motorola assume any liability arising out of the application or use of any product or circuit, and specifically disclaims any and all liability, including without limitation consequential or incidental damages. "Typical" parameters which may be provided in Motorola data sheets and/or specifications can and do vary in different applications and actual performance may vary over time. All operating parameters, including "Typical" must be validated for each customer application by customer's technical experts. Motorola does not convey any license under its patent rights nor the rights of others. Motorola products are not designed, intended, or authorized for use as components in systems intended for surgical implant into the body, or other applications intended to support or sustain life, or for any application in which the failure of the Motorola product could create a situation where personal injury or death may occur. Should Buyer purchase or use Motorola products for any such unintended or unauthorized application, Buyer shall indemnify and hold Motorola and its officers, employees, subsidiaries, affiliates, and distributors harmless against all claims, costs, damages, and expenses, and reasonable attorney fees arising out of, directly or indirectly, any claim of personal injury or death associated with such unintended or un authorized use, even if such claim alleges that Motorola was negligent regarding the design or manufacture of the parts. Motorola and  are registered trademarks of Motorola, Inc. Motorola, Inc. is an Equal Employment Opportunity/Affirmative Action Employer.

How to reach us:

USA / EUROPE / Locations Not Listed: Motorola Literature Distribution;
P.O. Box 5405, Denver, Colorado 80217. 1-303-675-2140 or 1-800-441-2447

JAPAN: Motorola Japan Ltd.; SPS, Technical Information Center, 3-20-1,
Minami-Azabu, Minato-ku, Tokyo 106-8573 Japan. 81-3-344-3569

Technical Information Center: 1-800-521-6274

ASIA / PACIFIC: Motorola Semiconductors H.K. Ltd.; Silicon Harbour Centre,
2, Dai King Street, Tai Po Industrial Estate, Tai Po, N.T., Hong Kong.
852-26668334

HOME PAGE: <http://www.motorola.com/semiconductors>



MOTOROLA

SUNSTAR 商斯达实业集团是集研发、生产、工程、销售、代理经销、技术咨询、信息服务等为一体的高科技企业，是专业高科技电子产品生产厂家，是具有 10 多年历史的专业电子元器件供应商，是中国最早和最大的仓储式连锁规模经营大型综合电子零部件代理分销商之一，是一家专业代理和分销世界各大品牌 IC 芯片和电子元器件的连锁经营综合性国际公司，专业经营进口、国产名厂名牌电子元件，型号、种类齐全。在香港、北京、深圳、上海、西安、成都等全国主要电子市场设有直属分公司和产品展示展销窗口门市部专卖店及代理分销商，已在全国范围内建成强大统一的供货和代理分销网络。我们专业代理经销、开发生产电子元器件、集成电路、传感器、微波光电元器件、工控机/DOC/DOM 电子盘、专用电路、单片机开发、MCU/DSP/ARM/FPGA 软件硬件、二极管、三极管、模块等，是您可靠的一站式现货配套供应商、方案提供商、部件功能模块开发配套商。商斯达实业公司拥有庞大的资料库，有数位毕业于著名高校——有中国电子工业摇篮之称的西安电子科技大学（西军电）并长期从事国防尖端科技研究的高级工程师为您精挑细选、量身订做各种高科技电子元器件，并解决各种技术问题。

更多产品请看本公司产品专用销售网站：

商斯达中国传感器科技信息网：<http://www.sensor-ic.com/>

商斯达工控安防网：<http://www.pc-ps.net/>

商斯达电子元器件网：<http://www.sunstare.com/>

商斯达微波光电产品网：[HTTP://www.rfoe.net/](http://www.rfoe.net/)

商斯达消费电子产品网：<http://www.icasic.com/>

商斯达实业科技产品网：<http://www.sunstars.cn/>

传感器销售热线：

地址：深圳市福田区福华路福庆街鸿图大厦 1602 室

电话：0755-83370250 83376489 83376549 83607652 83370251 82500323

传真：0755-83376182 (0) 13902971329 MSN: SUNS8888@hotmail.com

邮编：518033 E-mail:szss20@163.com QQ: 195847376

深圳赛格展销部：深圳华强北路赛格电子市场 2583 号 电话：0755-83665529 25059422

技术支持：0755-83394033 13501568376

欢迎索取免费详细资料、设计指南和光盘；产品凡多，未能尽录，欢迎来电查询。

北京分公司：北京海淀区知春路 132 号中发电子大厦 3097 号

TEL: 010-81159046 82615020 13501189838 FAX: 010-62543996

上海分公司：上海市北京东路 668 号上海赛格电子市场 2B35 号

TEL: 021-28311762 56703037 13701955389 FAX: 021-56703037

西安分公司：西安高新开发区 20 所(中国电子科技集团导航技术研究所)

西安劳动南路 88 号电子商城二楼 D23 号

TEL: 029-81022619 13072977981 FAX:029-88789382